



100 Royal Way  
 Temple, GA 30179  
 Phone (800) 520-6593

**SPECIFICATION DATA SHEET**

**MODEL No. 505R8**  
**Top Outlet Insulated Box**

Date:1/10/2024

**DIMENSIONAL DATA:**

<u>Register</u>		<u>Actual</u>
<u>Size</u>	<u>Collar Size</u>	<u>Box Dimensions</u>
8x4	4,5	10x6
10x4	4,5,6	12x6
10x6	4,5,6,7,8	12x8
12x4	7	15x7
12x6	6,7,8	14x8
14x6	7,8	16x8

**FABRICATION DATA:**

**Material:**  
 ASTM-A653 CS Type B Galvanized Steel,  
 G-30 Coating LFQ Chemical Treatment

**Gauge:** 30GA

**Assembly:**  
 New and improved 1 pc folded design to prevent air loss with a rectangular register opening. Includes a 1" 90 deg flange and 1/2" drywall lip for installation. The 3" collar is roll formed steel with 1/4" roll formed beading.

**Insulation:**  
 Johns Manville Duct Liner PM 2" Fiberglass Duct Liner (R8)

Operating temperature (max.) – ASTM C411 250°F (121°C)  
 Air velocity (max.) – ASTM C1071 6,000 fpm (30.5 m/sec)  
 Fungi resistance – ASTM C1338  
 Does not breed or promote Fungi resistance – ASTM G21 No growth

- ASTM C1071, Type I • ICC Compliant
- California Title 24 • ASHRAE 62 • MEA 353-93-M
  - SMACNA Application Standards for Duct Liners
  - NAIMA Fibrous Glass Duct Liner Installation Standard
  - Canada: CGSB 51-GP-11M and CAN/CGSB 51.11

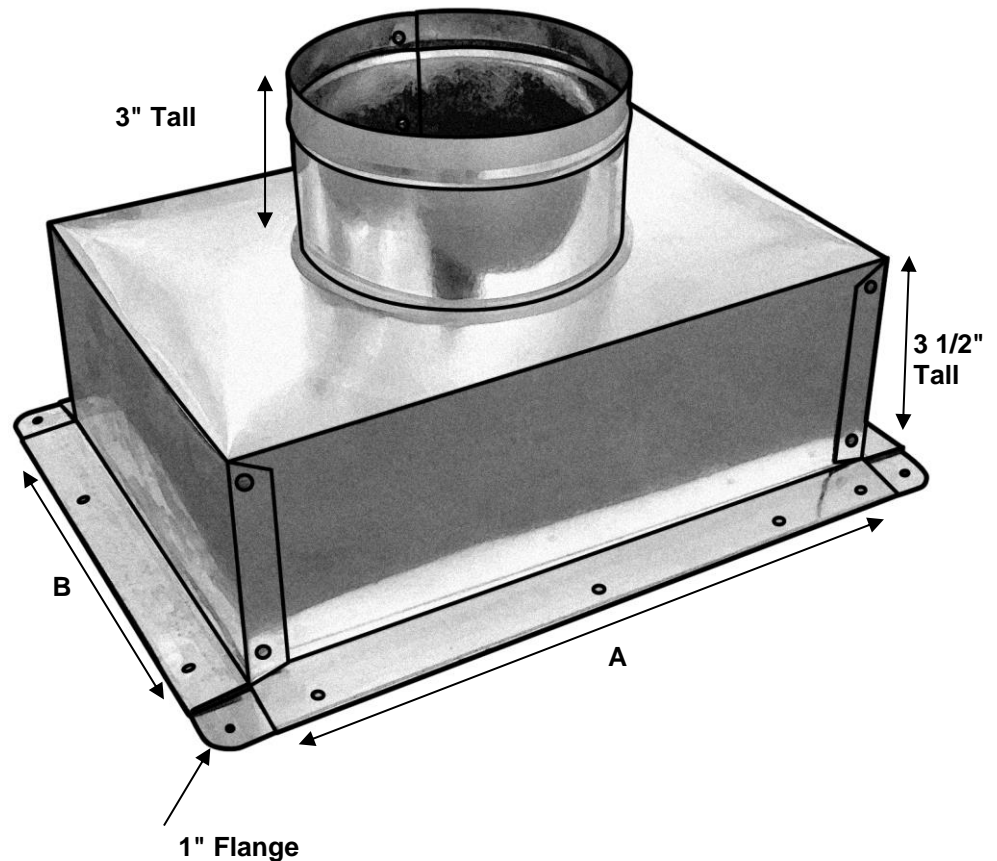

**Superior Quality, Superior Service, Superior Value.. that's the Royal Advantage**